

RWB-250K, 320K, 400K, 500K

HEAVY DUTY • DUAL DISC HYDRAULIC CLAMPING

The RWB,K-Series rotary tables are equipped with the finest Tsudakoma technologies. RWB tables utilize a powerful dual disc hydraulic clamping mechanism, and are available with an external booster when hydraulics are not in use. RWB-Series worm wheels are manufactured as an assembly consisting of the worm wheel, cross roller bearing, and the main spindle, resulting in unsurpassed accuracy.

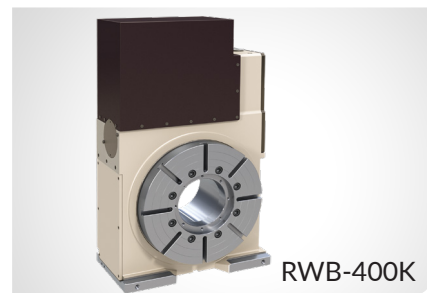

RWB-400K

Table Model		RWB-250K	RWB-250K,S	RWB-320K	RWB-320K,S	RWB-400K	RWB-500K	
Table diameter	mm	250	250	320	320	400	500	
Center height	mm	160	160	210	210	255	310	
Center bore	Nose Diameter	mm	105	105	150	150	220	
	Thru Diameter	mm	80	80	120	120	181	
Table T-slot width		12H7	12H7	14H7	14H7	14H7	18H7	
Guide block width		18h7						
Servo motor (Fanuc)*		Alpha 8i	Alpha 8is	Alpha 12i	Alpha 12is	Alpha 12i	Alpha 12i	
Maximum motor speed	rpm	4,000	4,000	4,000	4,000	4,000	4,000	
Speed reduction ratio		1/90	1/45	1/120	1/45	1/120	1/180	
Maximum table speed	rpm	44.4	88.9	33.3	88.9	33.3	22.2	
Inertia converted into motor shaft	x 10 ⁻³ kg·m ²	1.27	1.27	3.53	3.53	4.63	4.25	
Clamp system**		Hydraulic						
Clamp torque @500psi	Nm (ft. lbs.)	1,300 (958)	1,300 (958)	3,100 (2,284)	3,100 (2,284)	5,500 (4,053)	7,600 (5,601)	
Clamp torque @700psi	Nm (ft. lbs.)	2,000 (1,474)	2,000 (1,474)	4,700 (3,463)	4,700 (3,463)	8,000 (5,896)	11,000 (8,107)	
Indexing accuracy	arc sec.	±7						
Net Weight	kg (lbs.)	125 (286)	125 (286)	250 (550)	250 (550)	360 (792)	580 (1,276)	
Allowable wheel torque	Nm (ft. lbs.)	1,011 (745)	1,011 (745)	2,127 (1,567)	2,127 (1,567)	3,958 (2,917)	5,601 (4,131)	
Allowable work inertia	kg·m ²	7	7	19	19	36	112	
Allowable work weight		kg (lbs)	175 (385) [250 (550)]	175 (385) [250 (550)]	250 (550) [500 (1,100)]	250 (550) [500 (1,100)]	300 (660) [600 (1,320)]	600 (1,320) [1,200 (2,460)]
		N (lbf)	35,000 (7,700)	35,000 (7,700)	89,000 (19,580)	89,000 (19,580)	109,000 (23,980)	240,000 (52,800)
Allowable load when table clamped		Nm (ft. lbs.)	1,300 (958)	1,300 (958)	3,100 (2,284)	3,100 (2,284)	5,500 (4,053)	7,600 (5,601)
		Nm (ft. lbs.)	1,500 (1,105)	1,500 (1,105)	5,300 (3,906)	5,300 (3,906)	7,800 (5,748)	17,000 (12,529)

* Other motors & RPM available

** Booster optional

Specifications subject to change without notice

Dimensions

Drawings not to scale • Dimensions = mm

RWB-250K

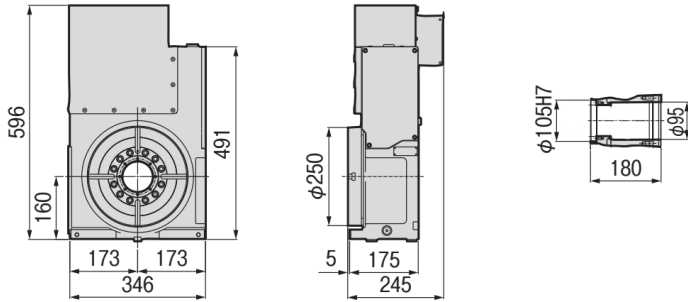

RWB-250K with booster & Hirschmann chuck



RWB-320K

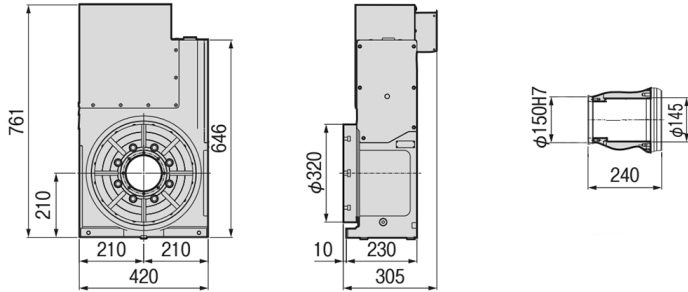

RWB-400K with Custom Cover & Swivel Box

A swivel connector is used to prevent cables from being entangled when the rotary table is mounted on a pallet.

RWB-400K

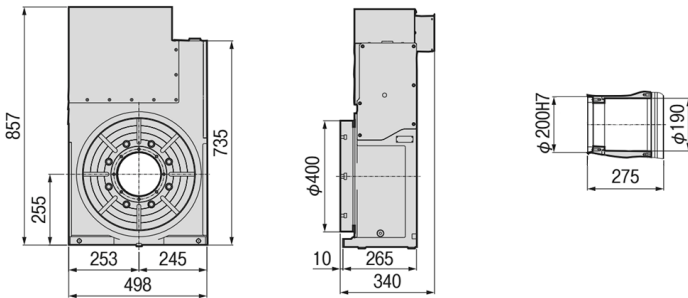

RWB-500K

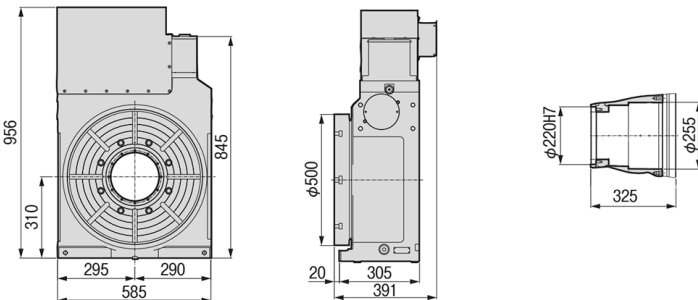

Options & Accessories

TPC NC Controller	p.62
Chucks	p.74
Tailstock	p.75
Support Spindle	p.77
Face Plate	p.77
Encoder / Scale	p.78
Pull Stud Device	p.79
Rotary Joint	p.79
Booster	p.80
PVC or Steel Cables	p.81

The dimensions above are for tables with a FANUC servo motor. Other motors available (dimensions may increase).

Clamping Block and Bolt

Dimensions = mm

	Type	Q'ty	T-Slot Width	A	B	C	D	E	F	G	H	I	J	K	L	M
RWB-250K	I	4	18	25	12	80	12	33	35	22	21	11	65	40	28	16
RWB-320K	I	4	18	30	15	90	16	31	43	25	21	11	70	46	28	16
RWB-400K	I	4	18	30	15	90	16	31	43	25	21	11	70	46	28	16
RWB-500K	I	4	18	40	20	110	18	42	50	25	21	11	70	46	28	16

Note: When using a machine with a T-slot pitch other than the above, use suitable clamping blocks and bolts that are available on the market, or order custom-made ones from KOMA (opt.)

Type I

