



ANGLE HEADS

Ideal for VMC and HMC to add an additional axis to the machine.



Finish your parts in the same setup without moving or re-clamping them



Ideal for milling, drilling, reaming, tapping, engraving, deburring, polishing, applications



Application & engineering layout drawing support provided by Koma



Standard

Adjustable

Custom

From small to large as well as high speed heads available



KOMA PRECISION
www.komaprecision.com

Tel: 1.800.249.5662
Fax: 860.623.4132

info@komaprecision.com
www.komaprecision.com

20 Thompson Road
East Windsor, CT 06088





Automatic insertion of angle head through machines tool changer

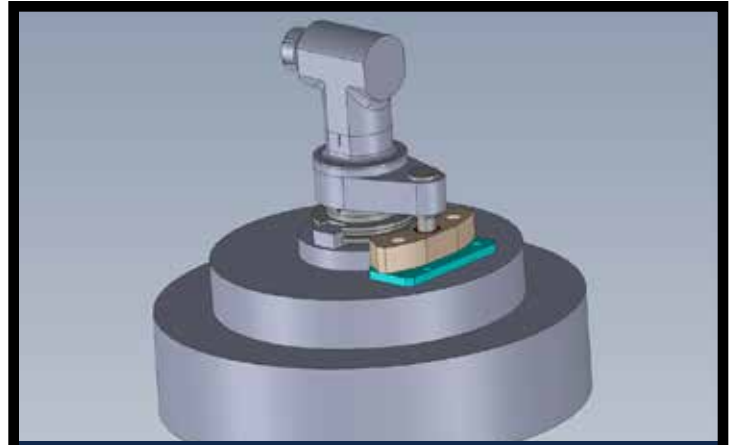

High pressure coolant through head up to 1450psi

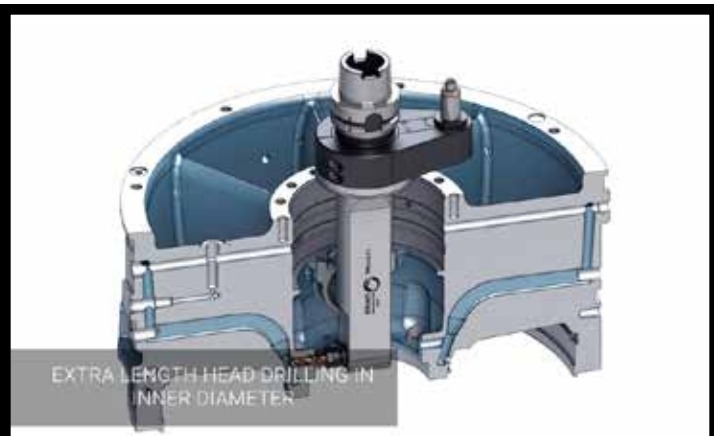

Different styles, length, 90 degree or adjustable heads available.

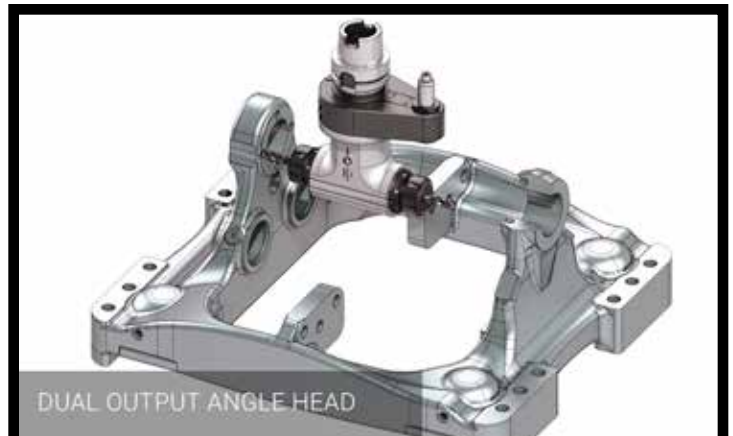

All common tool shanks available e.g. CAT, HSK, CAPTO, KM

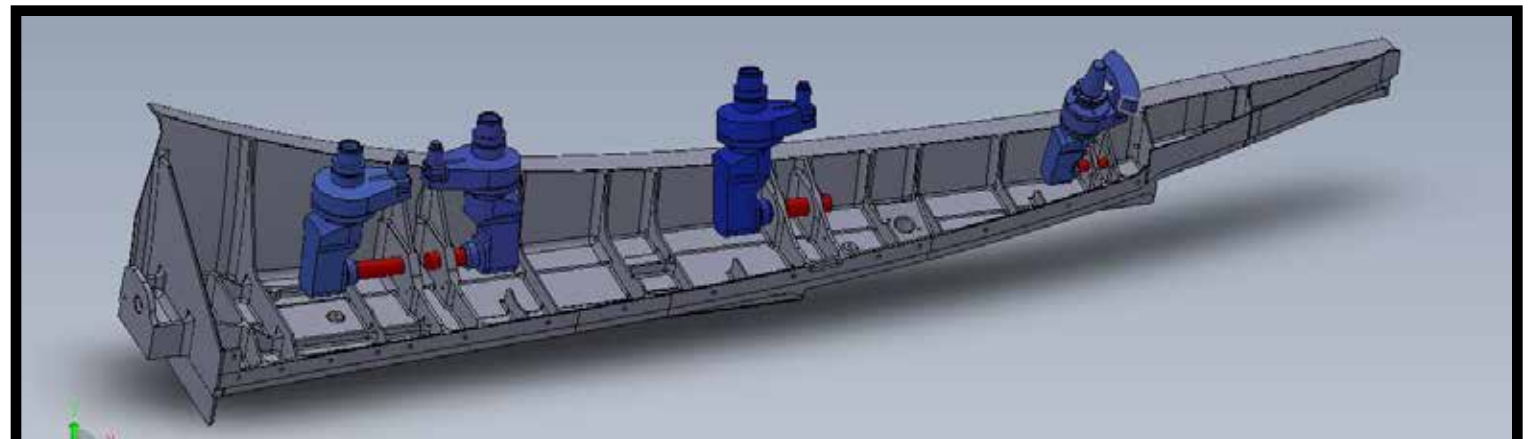

Different outlets from ER-8 to ER-40 as well as CAT40-CAT50 for heavy duty applications