

T90cn-2,5 2U

ACT9025D

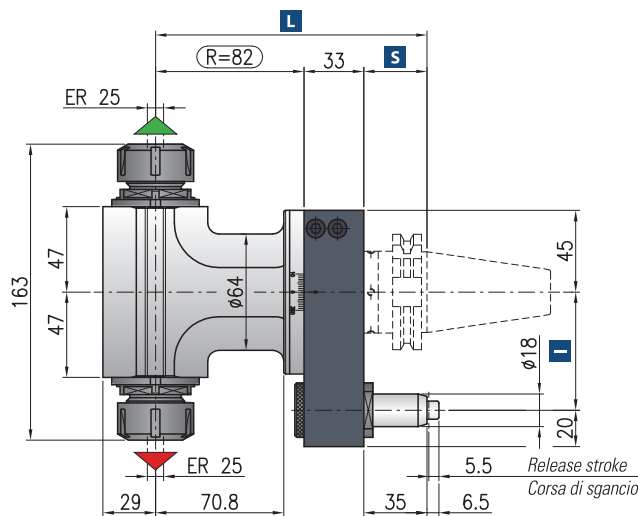

Minimum diameter without tool
Diametro minimo senza utensile

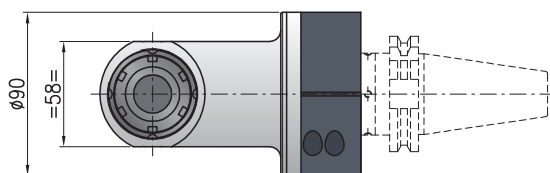
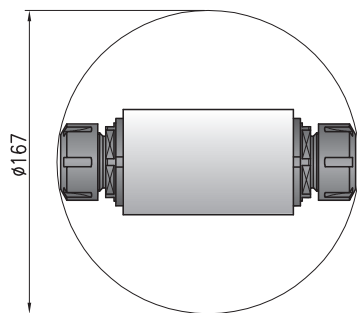

Retaining block / Tassello di ritegno / Stop-Block
NOT INCLUDED - NON INCLUSO

Direction of rotation same as machine spindle / senso di rotazione uguale al mandrino
 Direction of rotation opposite to machine spindle / senso di rotazione contrario al mandrino

- Ratio / Rapporto: **1:1**
- RPM / Velocità: **9.000 min⁻¹**
- RPM Dry running / Velocità a secco: **6.000 min⁻¹**
- Max. axial load / Max. carico assiale: **510 N**
- Torque / Momento torcente: **30 Nm**
- Weight / Peso: **6,4 kg**
- Collet / Pinza: **ER-25 (ø 1/16 mm)**

* STANDARD EQUIPMENT INCLUDES:

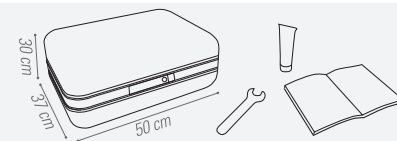

Shank/Cono	DIN-69871	CAT	MAS-BT	HSK	CAPTO	KM			
Size/Grandezza	40	50	40	50	63-80	100	C5-C6	C8	63
I	65-80	80-(110*)	65-80-(110*)	80-(110*)	65-80-(110*)	80-(110*)	65-80-(110*)	80-(110*)	65-80-(110*)
S	35	35	35	41	42	45	38	40	40
L	150	150	150	156	157	160	153	155	155

Dual contact spindles available/Disponibilità coni a doppio contatto

*optional

Non interchangeable input drive shank/ Coni di attacco non intercambiabili

Opzione / Option



bar max
12

Coolant through pin
Refrigerante attraverso il perno



min⁻¹
8.000

High speed optional RPM max.
Opzione alta velocità RPM max.



Ø mm
16

Arbor output
Porta fresa



Ø mm max.
16

Weldon output
Weldon