

## Angle Head Dimensions

Reference Only • Detailed drawings available upon request

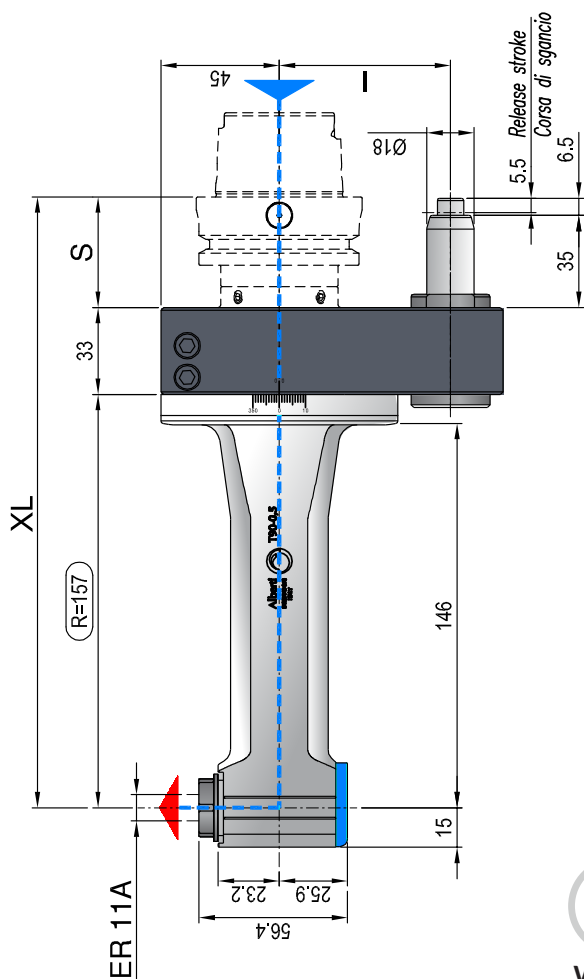

**Weight**  
9.68 lbs

- Direction of rotation opposite machine spindle
- Max coolant pressure 100bar, 1450 psi

- Also available without coolant.  
Maximum speed 8,000 min<sup>-1</sup>

## Technical Features



Ratio  
1.1



RPM  
10.000 min<sup>-1</sup>



Max. axial load  
150 N



Torque  
12 Nm



Tapping  
Max. M5



Collet  
ER-11

INPUT TAPER	SIZE	I	S	L
<b>DIN-69871</b>	40	65-80	35	220
<b>CAT</b>	50	80-(110*)	35	220
<b>MAS-BT</b>	40	65-80-(110*)	35	220
	50	80-(110*)	41	226
<b>HSK</b>	63-80	65-80-(110*)	42	227
	100	80-(110*)	45	230
<b>CAPTO</b>	C5-C6	65-80-(110*)	38	223
	C8	80-(110*)	40	225
<b>KM</b>	63	65-80-(110*)	40	225

## PLUS

- Dry running also possible (6.000 min<sup>-1</sup>)
- Increased torque thanks to bigger gears
- New drive system with pins for gear set
- One-hand wrench to tighten the tool