

## Angle Head Dimensions

Reference Only • Detailed drawings available upon request

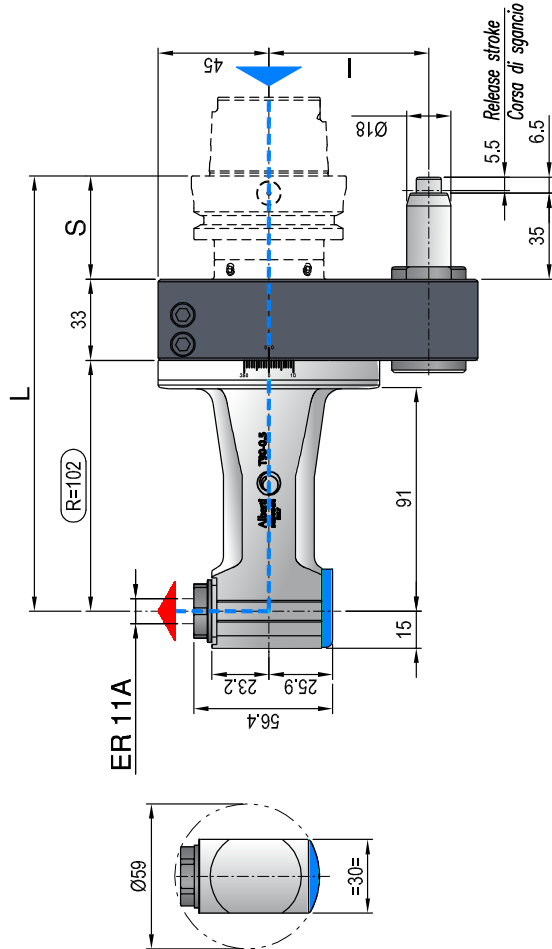

Direction of rotation opposite machine spindle

Max coolant pressure 100bar, 1450 psi



**Weight**  
8.8 lbs

## Technical Features



Ratio  
1.1



RPM  
10.000 min<sup>-1</sup>



Max. axial load  
150 N



Torque  
12 Nm

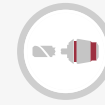

Tapping  
Max. M5



Collet  
ER-11A

INPUT TAPER	SIZE	I	S	L
<b>DIN-69871</b>	40	65-80	35	150
<b>CAT</b>	50	80-(110*)	35	150
<b>MAS-BT</b>	40	65-80-(110*)	35	150
	50	80-(110*)	41	156
<b>HSK</b>	63-80	65-80-(110*)	42	157
	100	80-(110*)	45	160
<b>CAPTO</b>	C5-C6	65-80-(110*)	38	153
	C8	80-(110*)	40	155
<b>KM</b>	63	65-80-(110*)	40	155

- Also available without coolant. Maximum speed 8,000 min<sup>-1</sup>

## PLUS

- Dry running also possible (6.000 min<sup>-1</sup>)
- Increased torque thanks to bigger gears
- New drive system with pins for gear set
- One-hand wrench to tighten the tool