

Angle Head Dimensions

Reference Only • Detailed drawings available upon request

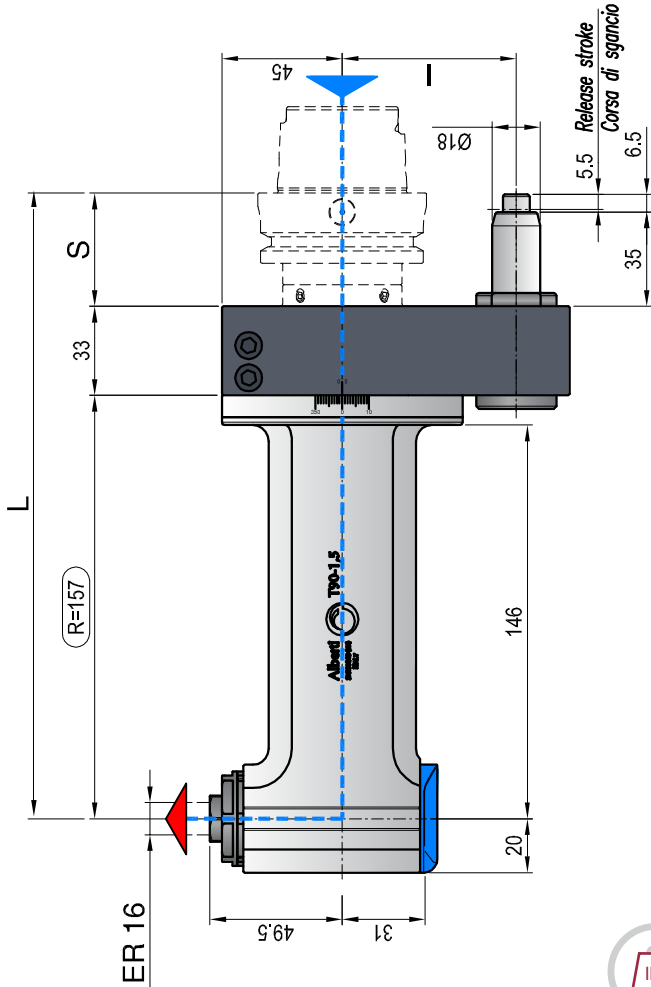

Direction of rotation opposite machine spindle.

Max coolant pressure 100bar, 1450 psi



Weight
11.44lbs

Technical Features



Ratio
1.1



RPM
10.000 min⁻¹



Max. axial load
250 N



Torque
25 Nm



Tapping
Max. M6



Collet
ER-16
(ø1/10 mm)

INPUT TAPER	SIZE	I	S	L
DIN-69871	40	65-80- (110*)	35	225
CAT	50	80-(110*)	35	225
MAS-BT	40	65-80- (110*)	35	225
	50	80-(110*)	41	232
HSK	63-80	65-80- (110*)	42	233
	100	80-(110*)	45	236
CAPTO	C5-C6	65-80- (110*)	38	228
	C8	80-(110*)	40	221
KM	50-63	65-80- (110*)	40	231

- Also available without coolant.
- Maximum speed 4,000 min⁻¹

PLUS

- Dry running also possible (8,000 min⁻¹)
- Increased torque thanks to bigger gears
- New drive system with pins for gear set
- One-hand wrench to tighten the tool