

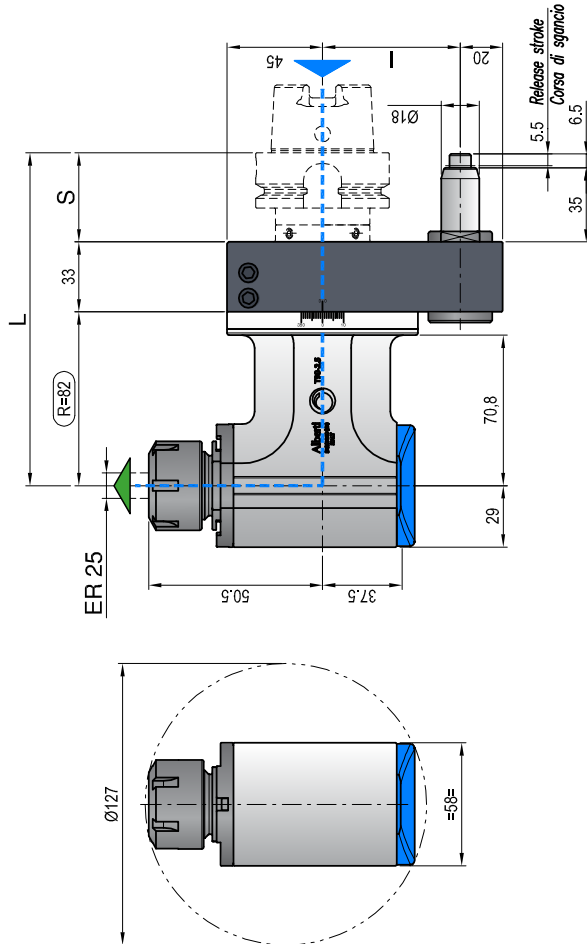

### Angle Head Dimensions

Reference Only • Detailed drawings available upon request



 **Weight**  
11.88lbs

-  Direction of rotation same as machine spindle
-  Max coolant pressure 100bar, 1450 psi

### Technical Features



Ratio  
1.1



RPM  
9.000 min<sup>-1</sup>



Max. axial load  
510 N



Torque  
50 Nm



Tapping  
Max. M12

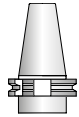
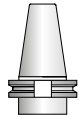
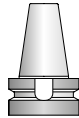
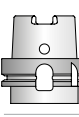
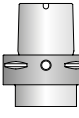
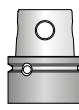

Collet  
ER-25  
(Ø1/16 mm)

INPUT TAPER	SIZE	I	S	L
 <b>DIN-69871</b>	40	65-80	35	150
 <b>CAT</b>	50	80-(110*)	35	150
 <b>MAS-BT</b>	40	65-80-(110*)	35	150
	50	80-(110*)	41	156
 <b>HSK</b>	63-80	65-80-(110*)	42	157
	100	80-(110*)	45	160
 <b>CAPTO</b>	C5-C6	65-80-(110*)	38	153
	C8	80-(110*)	40	155
 <b>KM</b>	63	65-80-(110*)	40	155

- Also available without coolant.  
Maximum speed 4,000 min<sup>-1</sup>

### PLUS

- Dry running also possible (6,000 min<sup>-1</sup>)
- Increased torque thanks to bigger gears
- New drive system with pins for gear set
- One-hand wrench to tighten the tool