

Angle Head Dimensions

Reference Only • Detailed drawings available upon request

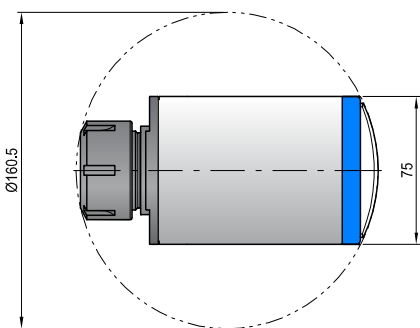

Weight
24.2lbs

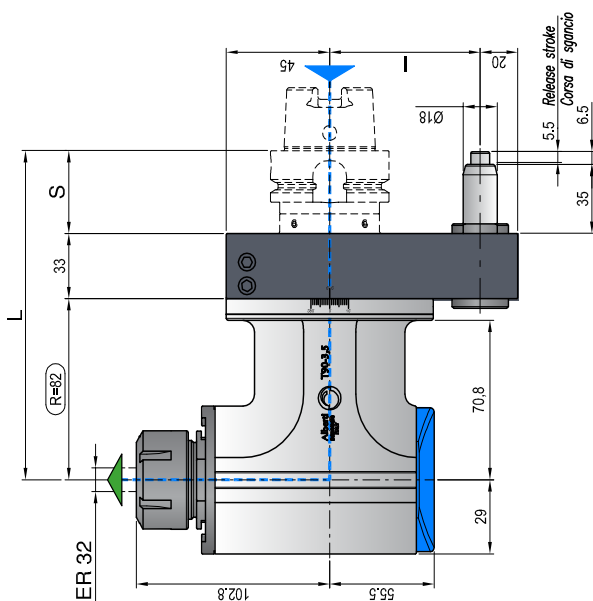

Direction of rotation same as machine spindle



Max coolant pressure 100bar, 1450 psi

Technical Features



Ratio

1.1



RPM

8.000 min⁻¹



Max. axial load

1.250 N



Torque

70 Nm



Tapping

Max. M16



Collet

ER-32
(ø2/20 mm)

INPUT TAPER	SIZE	I	S	L
DIN-69871	50	80-110	35	150
CAT				
MAS-BT	50	80-110	41	150
HSK	63-80	80-110	42	157
	100	80-110	45	160
CAPTO	C6	80-110	38	153
	C8	80-110	40	155
KM	63	80-110	40	155

- Also available without coolant.
Maximum speed 5,000 min⁻¹

PLUS

- Dry running also possible (5,000 min⁻¹)
- Increased torque thanks to bigger gears
- New drive system with pins for gear set
- One-hand wrench to tighten the tool