

Angle Head Dimensions

Reference Only • Detailed drawings available upon request

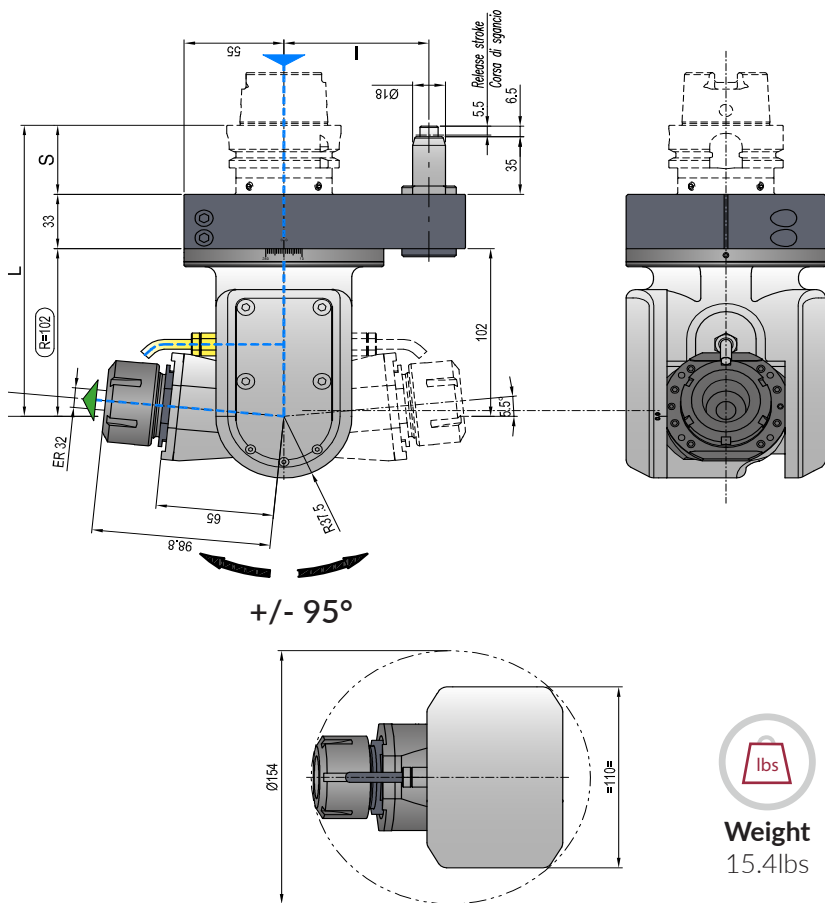

- ◀ Direction of rotation same as machine spindle
- ▶ Max coolant pressure 100bar, 1450 psi

- Also available without coolant. Maximum speed 4,000 min⁻¹

Technical Features



Ratio
1.1



RPM
6.000 min⁻¹



Max. axial load
510 N



Torque
30 Nm



Tapping
Max. M12



Collet
ER-25
(ø1/10 mm)

INPUT TAPER	SIZE	I	S	L
DIN-69871	40	65-80	35	158
CAT	50	80-(110*)	35	158
MAS-BT	40	65-80-(110*)	35	158
	50	80-(110*)	41	164
HSK	63-80	65-80-(110*)	42	165
	100	80-(110*)	45	168
CAPTO	C5-C6	65-80-(110*)	38	161
	C8	80-(110*)	40	163
KM	63	65-80-(110*)	40	163

*Dual contact spindles optional

PLUS

- Available without coolant. High Speed 4.000 min⁻¹
- Increased torque thanks to bigger gears
- New drive system with pins for gear set
- One-hand wrench to tighten the tool