

### Angle Head Dimensions

Reference Only • Detailed drawings available upon request

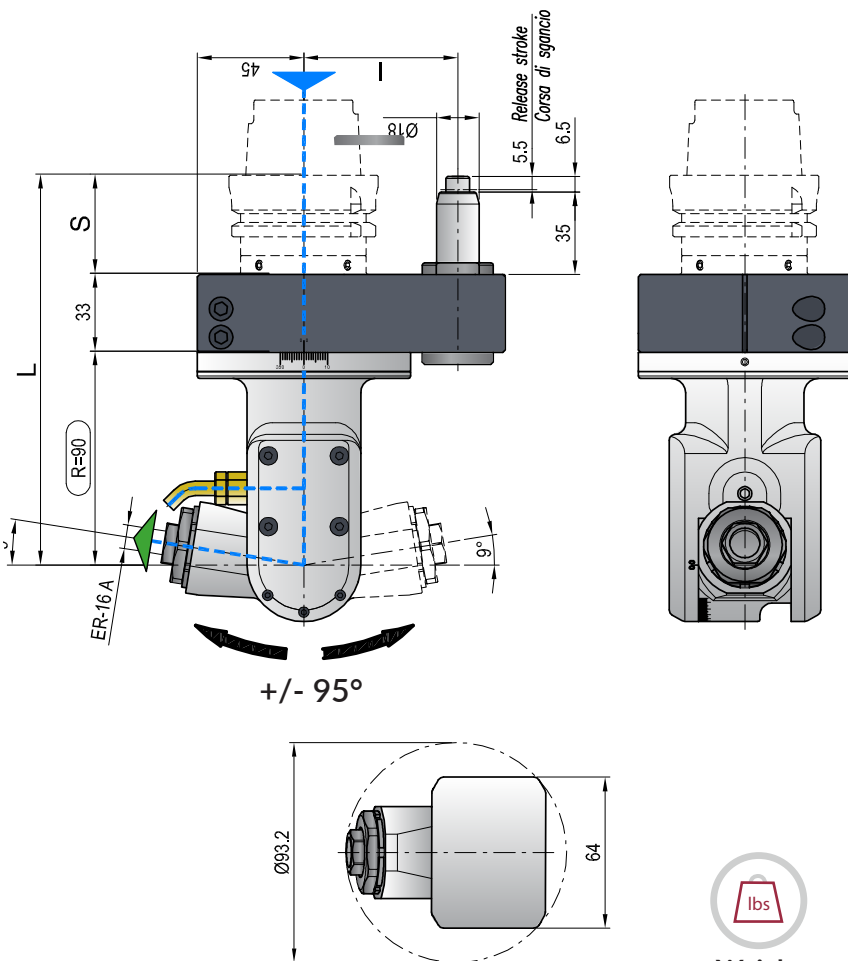

Direction of rotation same as machine spindle

Max coolant pressure 100bar, 1450 psi

- Also available without coolant. Maximum speed 4,000 min<sup>-1</sup>

### Technical Features



Ratio  
1.1



RPM  
8.000 min<sup>-1</sup>



Max. axial load  
450 N



Torque  
15 Nm



Tapping  
Max. M6



Collet  
ER-16A  
(ø1/10 mm)

INPUT TAPER	SIZE	I	S	L
<b>DIN-69871</b>	40	65-80-(110*)	35	158
<b>CAT</b>	50	80-(110*)	35	158
<b>MAS-BT</b>	40	65-80-(110*)	35	158
	50	80-(110*)	41	164
<b>HSK</b>	63-80	65-80-(110*)	42	165
	100	80-(110*)	45	168
<b>CAPTO</b>	C5-C6	65-80-(110*)	38	161
	C8	80-(110*)	40	163
<b>KM</b>	50-63	65-80-(110*)	40	163

\*Dual contact spindles optional

### PLUS

- Available without coolant. High Speed 4.000 min<sup>-1</sup>
- Increased torque thanks to bigger gears
- New drive system with pins for gear set
- One-hand wrench to tighten the tool

### Angle Head Dimensions

Reference Only • Detailed drawings available upon request

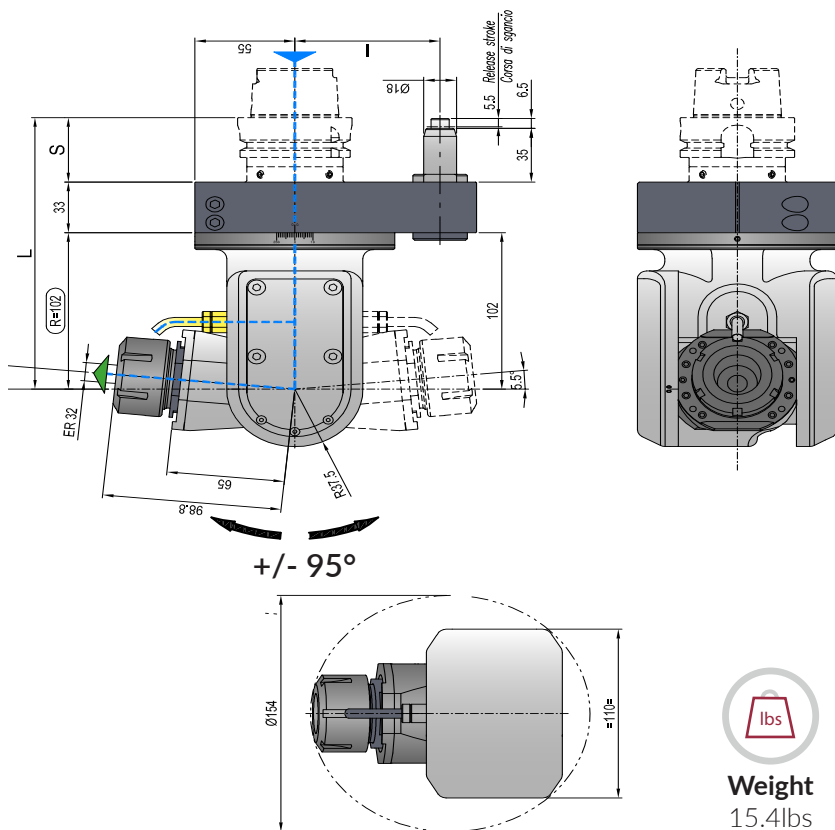

- ◀ Direction of rotation same as machine spindle
- ◀ Max coolant pressure 100bar, 1450 psi

- Also available without coolant. Maximum speed 4,000 min<sup>-1</sup>

### Technical Features



Ratio

1.1



RPM

6.000 min<sup>-1</sup>



Max. axial load

715 N



Torque

50 Nm



Tapping

Max. M16



Collet

ER-32  
(ø1/10 mm)

INPUT TAPER	SIZE	I	S	L
<b>DIN-69871</b>	50	80-110	35	170
<b>CAT</b>	50	80-110	41	176
<b>MAS-BT</b>	50	80-110	42	177
<b>HSK</b>	63-80	80-110	45	180
	100	80-110	38	173
<b>CAPTO</b>	C6	80-110	40	175
	C8	80-110		
<b>KM</b>	63	80-110	40	175

\*Dual contact spindles optional

### PLUS

- Available without coolant. High Speed 4.000 min<sup>-1</sup>
- Increased torque thanks to bigger gears
- New drive system with pins for gear set
- One-hand wrench to tighten the tool

### Angle Head Dimensions

Reference Only • Detailed drawings available upon request

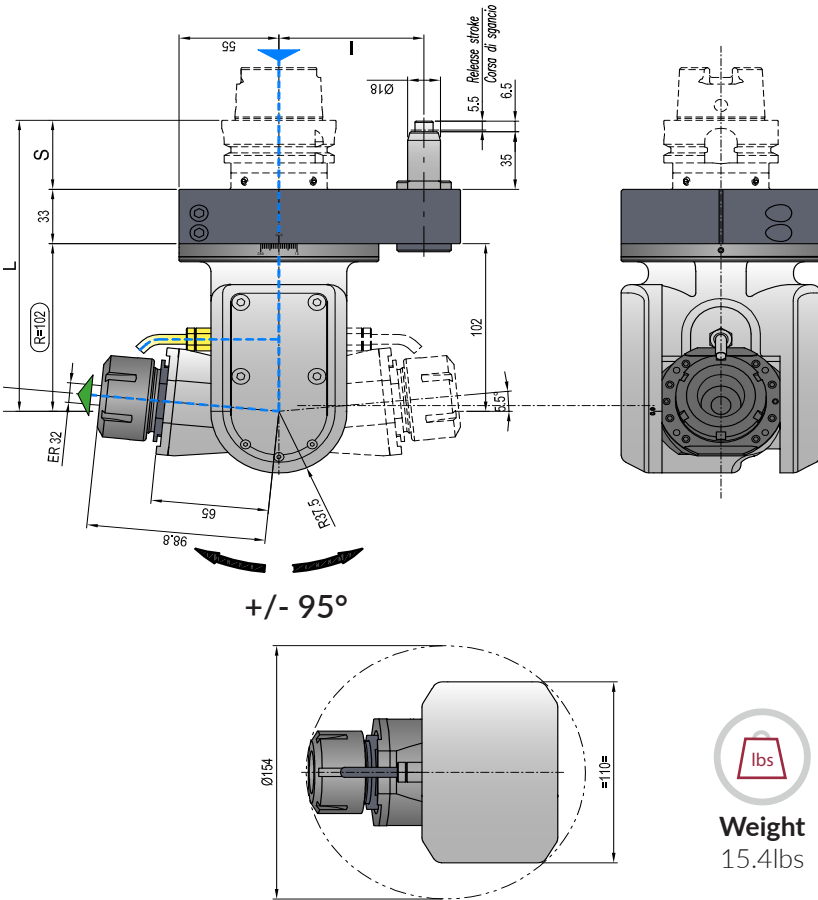

- ◀ Direction of rotation same as machine spindle
- ▶ Max coolant pressure 100bar, 1450 psi

- Also available without coolant. Maximum speed 4,000 min<sup>-1</sup>

### Technical Features



Ratio  
1.1



RPM  
6.000 min<sup>-1</sup>



Max. axial load  
510 N



Torque  
30 Nm



Tapping  
Max. M12



Collet  
ER-25  
(ø1/10 mm)

INPUT TAPER	SIZE	I	S	L
<b>DIN-69871</b>	40	65-80	35	158
<b>CAT</b>	50	80-(110*)	35	158
<b>MAS-BT</b>	40	65-80-(110*)	35	158
	50	80-(110*)	41	164
<b>HSK</b>	63-80	65-80-(110*)	42	165
	100	80-(110*)	45	168
<b>CAPTO</b>	C5-C6	65-80-(110*)	38	161
	C8	80-(110*)	40	163
<b>KM</b>	63	65-80-(110*)	40	163

\*Dual contact spindles optional

### PLUS

- Available without coolant. High Speed 4.000 min<sup>-1</sup>
- Increased torque thanks to bigger gears
- New drive system with pins for gear set
- One-hand wrench to tighten the tool