

## Angle Head Dimensions

Reference Only • Detailed drawings available upon request

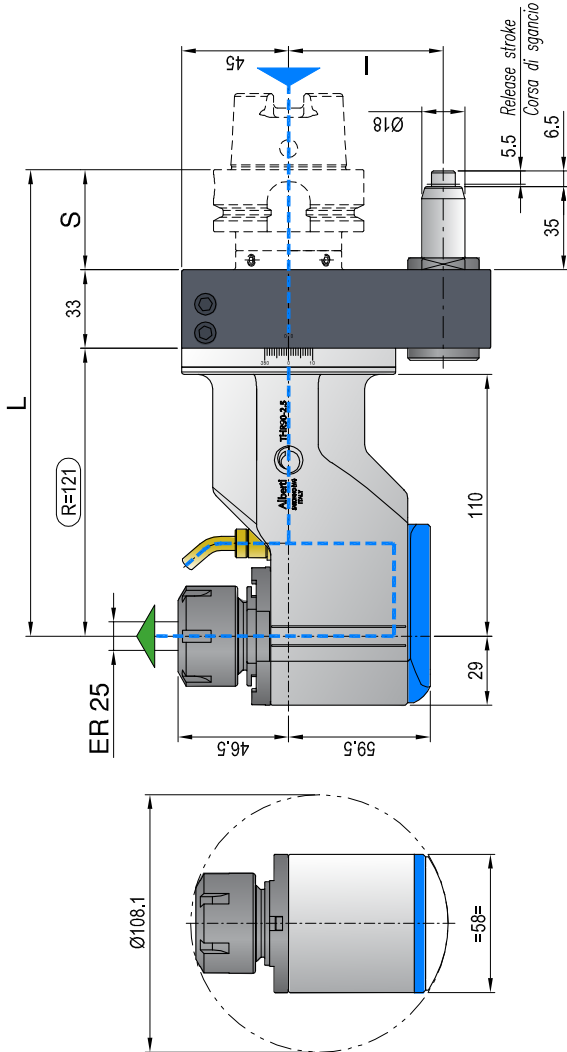

**Weight**  
14.3lbs

Direction of rotation same as machine spindle

Max coolant pressure 100bar, 1450 psi

- Also available without coolant. Maximum speed 6,000 min<sup>-1</sup>

## Technical Features



**Ratio**

1.1



**RPM**

9.000 min<sup>-1</sup>



**Max. axial load**

510 N



**Torque**

40 Nm



**Tapping**

Max. M12



**Collet**

ER-25  
(Ø1/16 mm)

INPUT TAPER	SIZE	I	S	L
<b>DIN-69871</b>	40	65-80	35	160
<b>CAT</b>	50	80-(110*)	35	160
<b>MAS-BT</b>	40	65-80-(110*)	35	160
	50	80-(110*)	41	166
<b>HSK</b>	63-80	65-80-(110*)	42	167
	100	80-(110*)	45	170
<b>CAPTO</b>	C5-C6	65-80-(110*)	38	163
	C8	80-(110*)	40	165
<b>KM</b>	63	65-80-(110*)	40	165

\*Dual contact spindles optional

## PLUS

- Available without coolant. High Speed 6.000 min<sup>-1</sup>
- New drive system with pins for gear set
- Increased torque thanks to bigger gears
- One-hand wrench to tighten the tool